

vees signature

 **Delicooker[®]**

User Manual

Thank you for purchasing VEES Delicooker series products. Please read this manual before using to ensure the product is being properly operated, used and maintained. Please keep this manual properly for future perusal. The VEES Delicooker series products will rand new, simple as well as a wonderful smoke-free cooking experience.



Cautions

Before use VEES Delicooker

1. Unpack and inspect. If you find any damage to the Delicooker, do not install and use it, contact our customer service department immediately.
2. Use good quality socket, as poor quality socket may lead to the burning of the Delicooker or affecting its normal operation.
3. When the socket wire is damaged, wire or power plug is not securely plugged in the socket, do not use the Delicooker.
4. Do not bend, bind or use excessive force to the wire to avoid damaging them.
5. Do not plug in a socket already plugged with several appliances; the power shall not exceed the limit of the socket.
6. Do not use wet hand to plug in the socket or turn on the power plug.
7. Do not use the Delicooker in a damp place or near the fire, nor in places with high-temperature, such as near the gas or kerosene cooker.
8. Do not place any detergent or inflammable materials underneath the Delicooker.
9. Before using the Delicooker, wipe and clean the water and dirt at the bottom of cooker to prevent the panel from turning yellow in the heating process.
10. This Delicooker comes with a special environmental packaging, so please do your part to protect the environment by collecting the package for recycling.

When using VEES Delicooker

1. Do not place Delicooker on an unstable surface.
2. Do not block ventilation holes of the Delicooker to avoid over-heating of the Delicooker.
3. Do not use the Delicooker in places accessible to children. Children and elderly people can only use the Delicooker under adults supervision.
4. Place food in cookware for warming, not directly on the Delicooker surface.
5. Do not heat inflammable fabric and paper on the Delicooker surface.
6. Do not heat or over-heat an empty cookware.
7. Sealed foods, such as canned food, should not be heated unopened to avoid the risk of explosion caused by expansion of the cans.

8. Do not remove the Delicooker with cookware on it.
9. Do not use the Delicooker in places with little space in the surrounding, and make sure that the front portion and the left and right sides of the Delicooker are clean.
10. Do not insert metal wire and foreign objects into the gap of ventilation holes of the Delicooker.
11. Do not let things fall on the Delicooker surface. If there are cracks on the Delicooker surface or the surface is damaged, immediately turn off the power, unplug and sent it for repair.
12. Do not place fatty or oily foods in the Delicooker as oil gets heated up easily and may cause a fire. If fire is caused by oil, instead of putting it off with water, cover the Delicooker with a lid and shut it down immediately.

After using VEES Delicooker

1. After using, adjust the power to the lowest, turn off the power, then remove the cookware.
2. Remove hot cookware from the Delicooker or the heat from the hot cookware will affect and damage the Delicooker's internal structure and shorten its life.
3. Do not touch the Delicooker surface after cooking to avoid being scalded as the heat generated by cookware will transfer to the Delicooker surface.
4. Do not put wire on the Delicooker surface to avoid wire insulation and burning on Delicooker surface.
5. Do not unplug by pulling out wire.
6. Disconnect the power when you are not using the Delicooker.

Basic Principles

The Delicooker vertical heat radiation and heating will meet the various cooking requirements; it operates with touch control, without a magnetic field radiation and does not interfere with other electrical appliances. It starts without instantaneous current and is the best choice for the modern family. The personalized design of the product, the use of imported materials coupled with advanced technology, so that the product has a safe and reliable performance, bringing comfort to your life and helps you to fully enjoy the happy life. It does not harm your health and it has many safe and protective devices, making your cooking more easier, more safety.

Product Specifications

VEES Delicooker

Model	Rated Voltage	Rated Power
VCH-PLUTO-2CH	220-240V~50/60Hz	4400W (2200W+2200W)

VEES Delicooker

DuoR Delicooker - VCH-PLUTO-2CH



How to Install

The size of a mounting hole on the table should be in the same size with that respective model (the diagram below is the diagram according to different models.) Please provide a space of about 55mm around the mounting hole, the table should be at least 30mm in thickness. Choose heat-resistant materials to avoid the table top from distorting that may be caused by the heat generated by the Delicooker.

VCH-PLUTO-2CH

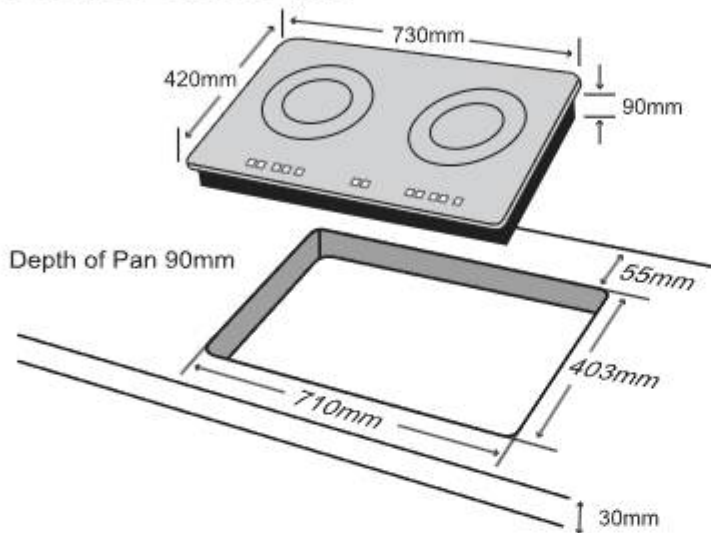

Model : VCH-PLUTO-2CH
 Heating Zone Diameter : 200mm, 200mm
 Surface Dimension : 730mm x 420mm
 Cut of Dimension : 710mm x 403mm

Connection of power lines should be carried out in accordance with the relevant national standard. The connection method is shown in (1):

Service Voltage	Connecting Mode of Power Supply			
	1	2	3	
220-240V 50/60Hz	L	N		

Installer must ensure the correct electrical connections being done in consistent with the safety requirements. The cable can not be bent or compressed, must be regularly checked and replaced by a professional technician.

Power Connection

The requirements of using power lines are:

VCH-PLUTO-2CH : 3G x 2.5mm²

(number of cores x nominal cross-section) .

During installation, please use the 3-hole socket. The 3-hole socket to be installed in a place accessible to the people or easy to control, at a height of 1.3m-1.5m, and 3-hole socket required to be equipped with is of specification 25A.

To ensure the firm installation of the Delicooker on the table, you may use the balanced seal provided, as shown in the diagram below.

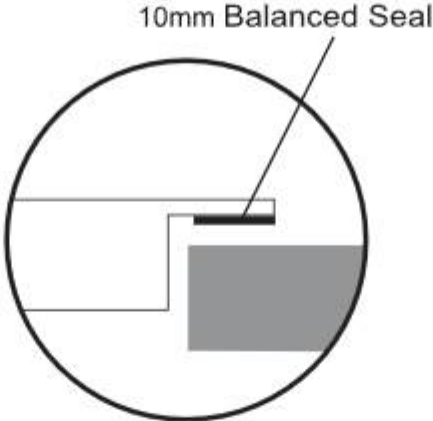

VEES Delicooker

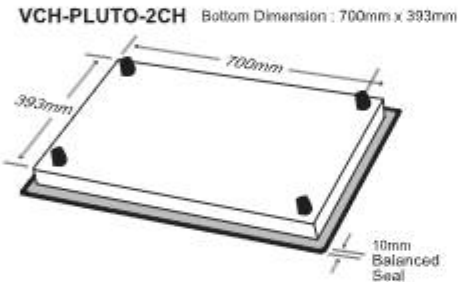

- Note:
- A safe distance of more than 760mm between the surface of the Delicooker and a cabinet should be kept.
 - The Delicooker must be installed by a professional technician.

Operation and Use (VCH-PLUTO-2CH)

Indications on VEES Delicooker

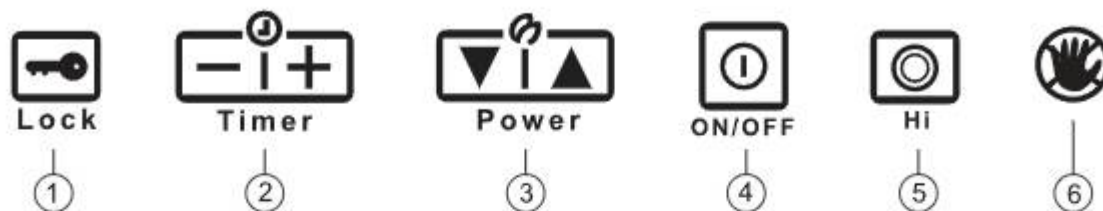

① Locking System

The lock system is to prevent incorrect operation.

② Timer

This function can be used as time schedule for cooking (5 minutes - 480 minutes).

③ Power

To adjust power level from 1 to 9.

④ ON/OFF

The pilot lamp will flickering when the power is on and the Delicooker is on when the button is pressed (at this time, function selection pilot lamp will flickering and is on standby). It shuts down when the button is pressed again.

⑤ Cooking Zone Setting

⑥ Residual Heat Indicator

Which shows that the surface area is still hot. Therefore do not touch the surface area when the indicator light is ON.

* Auto shut-off

After 30 minutes of being idle, Auto shut-off takes its effect.

How to Operate the VEES Delicooker (VCH-PLUTO-2CH)

VEES Delicooker is controlled by simply touching the control area on the surface of the ceramic glass.

Ready to use

Turn on the control switch after switching on the power supply. The pilot lamp of power supply is flickering, a "beep" sound will be heard and the electric range is ready to work.

Operation Steps



1. Select cooking zone area within 1 minute.
2. Lightly touching the ▼ or ▲ control key on the range area. The monitor will display the digit(s).

Note: If selection is not made within 1 minute, the appliance will automatically return to standby status.

Once the area to be used is selected, choose the power level.
(For example: Level 7)



3. Lightly touch ▼ or ▲ control key.

By lightly touching the ▼ , Level 4 working status will be set.
By lightly touching the ▲ , Level 9 working status will be set.



4. If the cooking zone is consisting of 2 different power stovesets, it works in 1000W automatically, lightly touch " Hi " the cooking zone will turn to 2200W. Lightly touch " Hi " again the cooking zone will back to 1000W.

Turning Off the Heating Zone



Touch the switch of the heating zone area to turned off until the number "0" is displayed. Lightly touch the ON/OFF to switch off the cooktop at any time.

How to start the Time-setting Function (For example: Set 40 minutes timing)



1. Lightly touch – or + control key. The indicator flashes " 0 " minutes.
By lightly touching the + 4 times, time setting will be 40 minutes.

If the user want to change the heating time, just lightly touch – or + , until you choose the time needed.

2. Heating time over.
While heard for "BB" buzzers, showing the "00" minute, the cooking zone will shut off automatically and the function is cancelled.

How to start the Locking System



1. Lightly touch the control key for more than 2 seconds.
2. A "Beep" sound will be heard.
3. The symbol pilot lamp will ON (located above the control key) indicating the locking system is activated.

Note: All control key cannot be used while in the locked status. However the ON/OFF switch will function.

How to unlock the system

Lightly touch the control key for more than 2 seconds again and the "Beep" sound will be heard. The symbol pilot lamp will OFF and the locking system has been turned off.

Choice of Cookware

The suitable cookware:

1. Iron cookware (enamel, cast iron, stainless iron), stainless steel pan.
2. The diameter of the bottom of the pan should be between 12CM-26CM. Try to use cookware with the size fitting with the burner. Cookware with the bottom of the same size with the burner will transfer heat and function with efficiency. Diameters for respective burners are: 14CM, 18CM and 23CM.

Use of Cookware

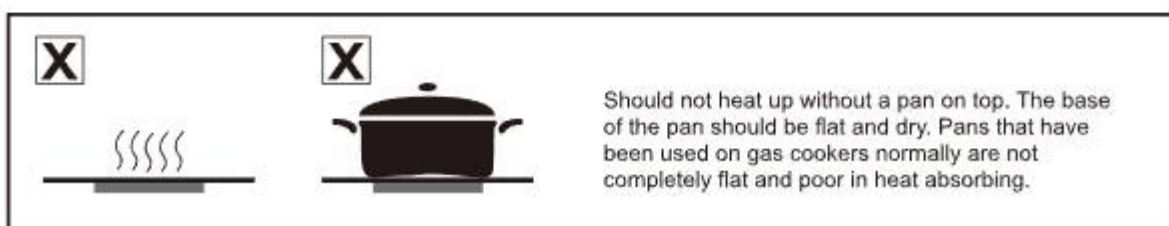
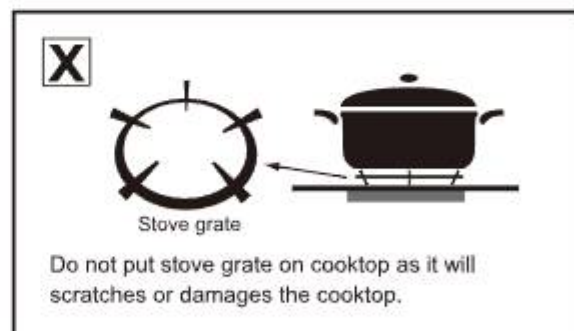
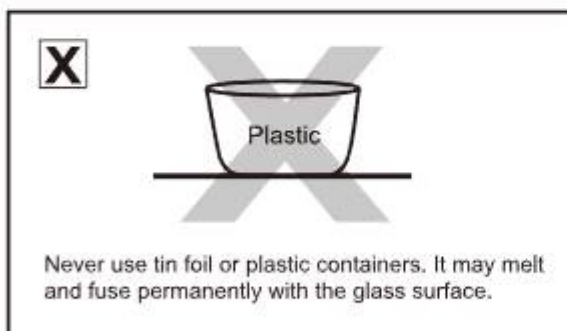
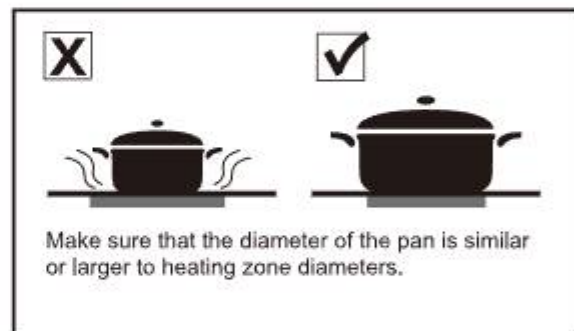
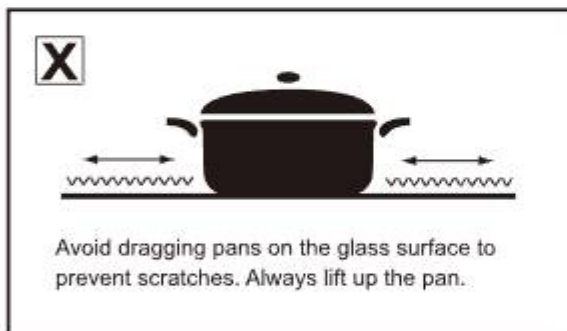
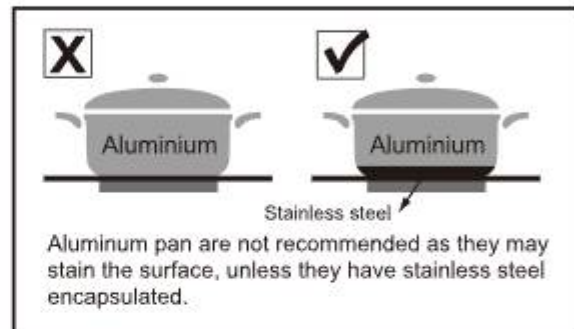
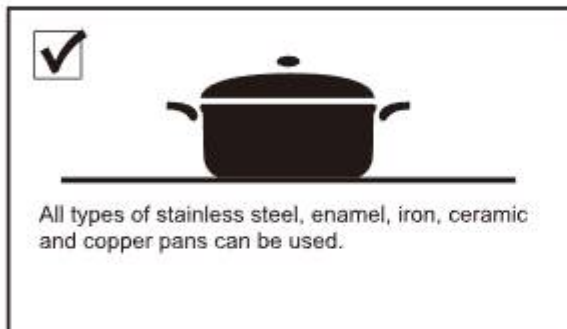

(A) Power requirements

1. Use a 3-hole socket with earth wire which meets the standard technical indicators. Do not replace it with a 2-hole socket without the earth wire as the 2-hole socket is not firm, tends to loose and does not meet the national standard, and is also more dangerous.
2. Socket should not be located right above the Delicooker to prevent the socket from heating up and disrupting power supply.
3. Electrical appliances which make sudden changes in electrical current such as welding machine, drill, hammer etc., or other hi-power electrical appliances such as refrigerator, washing machine, and water heater, should not be used to avoid damaging the Delicooker. Try to use stable power and try not to switch on or off other electrical appliances at the same time when the Delicooker is in operation to avoid damaging the Delicooker.

(B) Heat ventilation of the VEES Delicooker

There is a certain temperature within the Delicooker when it is in operation, for the Delicooker Operate better and normal and to extend its life, the heat must be ventilated by ensuring that the Delicooker is placed in a place with good ventilation and cooling.

(C) Cleaning and maintenance of the VEES Delicooker

1. Please unplug the power cord before cleaning. Cleaning work should be started when the Delicooker is completely cooled down.
2. After using, wipe the Delicooker surface with a damp cloth. For easy removal of the oil, wipe with neutral detergent and then clean it with damp cloth.
3. Do not directly rinse the Delicooker with water or immerse it in water.
4. Always keep the Delicooker clean to prevent cockroaches and insects from entering, resulting in its failure.
5. Do not use high pressure or steam jet vacuum cleaner to clean the Delicooker.

7. Do not put stove grate on cooktop as it will scratches or damages the cooktop.
8. Do not use pot with rough bottom, as it may scratch the Delicooker surface. Users are advised to check the pot bottom before using.
9. Do not put hot frying pan or oven tray on the control panel or other part of the Delicooker to avoid damaging the Delicooker.
10. Do not wash vegetables on the Delicooker surface to prevent sand, salt or sugar from scratching the Delicooker surface.
11. Do not hang any hard or sharp objects above the Delicooker as they may drop and damage the Delicooker.
12. Do not clean the Delicooker by using wire ball, brush or spray mist or rust cleaning detergent with corrosive materials.
13. The Delicooker may be damaged due to the following circumstances, but its normal operation will not be affected:
 - i. Rusty : a result of spill over and the solution of sugar or food with high sugar.
 - ii. Scratch: can be caused by salt, sugar and sand etc., or the rough bottom of the pot.
 - iii. Fading : due to rubbing of the pot and the use of unsuitable cleaning materials.

The above damage is due to incorrect use, it has nothing to do with the product technology, therefore it is not under warranty.

(D) Unusual circumstances

In the course of using the Delicooker, if unusual circumstances occur, such as abnormal shutdown or warning sound etc., stop using the Delicooker and contact with the Customer Service department immediately. If you notice that there is a malfunction, get the help from professional maintenance staff. Do not disassemble the Delicooker by yourself.

(E) Store the Delicooker

If not using the Delicooker for a long time, clean and dry it, and then store it in a place with good ventilation. Desiccant and pesticides can be placed inside the package. Do not press it as it can be reused.

(F) Protect the cooktop

Suggest to purchase crash frame to prevent the edges and corners of cooktop from being accidentally hit by hard object.

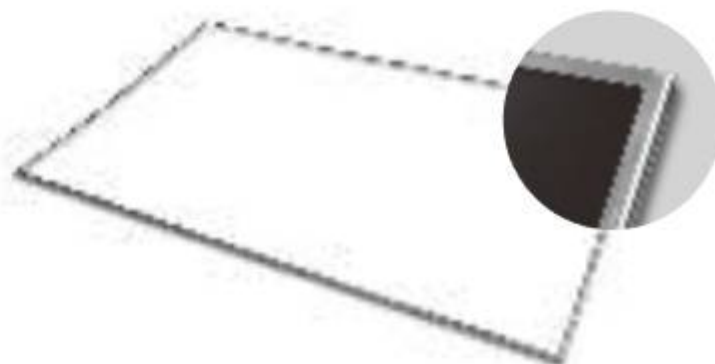

Warranty

1. During the one-year warranty period (based on receipt date), though users are operating the Delicooker in accordance with instructions given in the manual, fault is still found in the Delicooker, the company will provide free repair.
2. To enjoy the free maintenance service, users must produce official receipt.
3. During the warranty period, in the event of any incorrect use and the failure to produce receipts, a reasonable and appropriate maintenance fee will be charged.
4. The company will provide maintenance services in respect of the fault occurred after warranty period, and will charge a reasonable fee.
5. Users are not entitled to free replacements and are not under warranty service when the followings occur:
 - a. Glass and decorative items;
 - b. Damage due to human error or incorrect use;
 - c. Damage due to errors, improper use or accident;
 - d. Damage occurred after the prescribed time limit.
6. Before calling the Customer Service Centre for assistance, please check the fault yourself first and find out the cause.
7. Please provide the product information to the Customer Service Centre. The information may be found from the surface and bottom of the Delicooker or documents in the package. With respect to damage caused by incorrect use or fault, our service centre will charge a reasonable and appropriate fee.
8. Our products comply with the current safety standard of household appliances and can only be maintained by qualified technicians. **WARNING!** Please do not modify the internal structure of the Delicooker.
9. Return shipping for warranty / service work is the customer's responsibility cost for shipping while back to the customer is covered by Vees within the Continental Wilayah Persekutuan Malaysia. Any expedited shipping will be at the owner's expense.

Troubleshooting

The faults	Inspection and management
The Delicooker not heated, the display screen is off.	Whether the power is turned on? Whether the plug is inserted properly? Whether the socket is damaged? Whether all the burners are having the same problem?
Circuit breaker trips when power is on.	Whether the use of power exceeds the power rating?
Power light flashes, then the light is off.	For cooking at high power for a long period, the Delicooker will start its automatic protection device to avoid overheating of internal components. When the light stops flashing, the user can continue to use it.

Disclaimer:

The company in publishing and printing of this manual has done its best to ensure that all informations and its contents are correct, if there are errors or omissions, we shall not be held responsible. In addition, with respect to any technical improvement of the product, the information will be given in the revised edition of the manual.

Service Centre:
F-06-03, Setiawalk, Pusat Bandar Puchong,
47160 Puchong, Selangor, Malaysia.
Service Hotline: 03-8600 1648